

SEM206P USER GUIDE

SMART HEAD MOUNT Pt100 TRANSMITTER
TWO WIRE (4 to 20) mA OUTPUT

Important - Please read this document before installing.

Every effort has been taken to ensure the accuracy of this document, however we do not accept responsibility for damage, injury, loss or expense resulting from errors and omissions, and we reserve the right of amendment without notice.

IMPORTANT - CE & SAFETY REQUIREMENTS

Product must be mounted inside a suitable enclosure providing environmental protection to IP65 or greater.

To maintain CE EMC requirements, input wires must be less than 3 metres.

The product contains no serviceable parts, or internal adjustments. No attempt must be made to repair this product. Faulty units must be returned to supplier for repair.

This product must be installed by a qualified person. All electrical wiring must be carried out in accordance with the appropriate regulations for the place of installation.

Before attempting any electrical connection work, please ensure all supplies are switched off.

ABSOLUTE MAXIMUM CONDITIONS (To exceed may cause damage to the unit).	
Supply Voltage	± 30 V dc (Protected for over-voltage and reverse connection)
Current with over-voltage	± 100 mA
Input Voltage	± 3 V between any terminals
Ambient	Temperature (-40 to 85) °C, Humidity (10 to 95) % RH (Non-condensing)



1~DESCRIPTION.

The device is an in-head transmitter that accepts Pt100 temperature sensors and converts sensor output over a configured range to a standard industrial (4 to 20) mA transmission signal.

PC configuration allows the user to select range, units and burnout direction, without requiring calibration equipment. Configuration is performed quickly using our USB port-driven configurator.

Calibration set up may be saved as a file on the PC for later use. If required, the desired range can be specified at the time of order, removing the need for user configuration.

2~RECEIVING AND UNPACKING.

Please inspect the packaging and instrument thoroughly for any signs of transit damage. If the instrument has been damaged, please notify your supplier immediately.

3~SPECIFICATION.

Refer to data sheet for full specification.

Configuration	
Factory default	(0 to 100) °C, upscale burnout, 0.0°C offset

4~INSTALLATION AND WIRING.

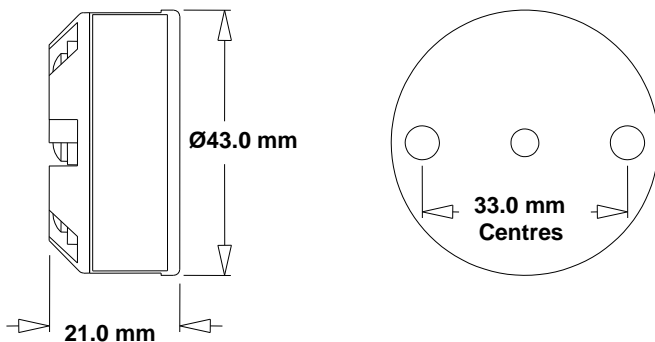

Mounting holes: two holes 5.5 mm diameter, 33 mm centres.
Centre hole sensor wire entry 4 mm.

4.1~MECHANICAL.

The unit is mounted using two 5.5 mm holes, on standard 33 mm fixing centres and will fit a DIN standard termination head. The unit must be installed with adequate protection from moisture and corrosive atmospheres.

Care must be taken to ensure the unit is located so the ambient temperature does not exceed the specified operating temperature.

4.2~ELECTRICAL.

Electrical connections to the transmitter are made to the screw terminal provided on the top face. The transmitter is protected against reverse connection and over-voltage. If no sensor (input) connection is made, the transmitter will go into either up or down scale output current, depending on configuration setting.

TURN OFF SUPPLY BEFORE WORKING ON ANY ELECTRICAL CONNECTION

Input sensor connections.

Pt100 wire must be equal length and type.

Sensor connections are as follows: to maintain BS EN61326 compliance, sensor wires must be less than 3 metres. All sensor connections must be isolated from ground.

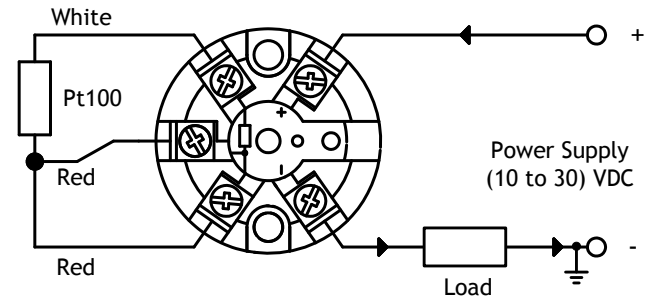

(4 to 20) mA Loop connections.

Ensure all other aspects of the installation comply with the requirements of this document. To maintain CE compliance, the (4 to 20) mA current loop must be tied to a local earth at one point; this is normally at the power supply.

Use twisted pair or screened cables for cable lengths greater than 30 metres. Maximum cable length 1000 metres.

5~USER CONFIGURATION.

IMPORTANT

READ COMPLETE SECTION BEFORE ATTEMPTING CONFIGURATION.

IMPORTANT

Do not attempt to configure the unit when connected to a loop supply.

A USB configuration module is required for connecting the unit to the PC. Refer to your supplier for details.

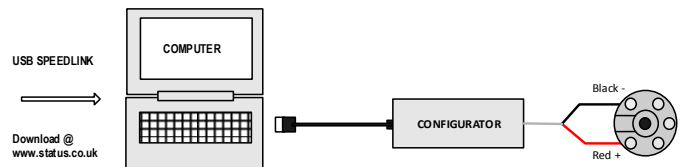

Install the software and connect the USB configuration module

Configuration steps	
1	Install the software and connect the USB configuration module to the PC.
2	Connect the configuration module to the device (removed from any loop supply).
3	Select the correct programming page in the software.
4	Read the unit configuration into the software.
5	Re-configure or adjust configuration options as required.
6	Send the new configuration to the unit.

Configuration options in software	
Temperature units	°C or °F
Low range 4 mA	Any °C/°F point within range
High range 20 mA	Any °C/°F point within range
Sensor fail	Burnout high or low
Offset	In °C or °F



*Status Instruments Ltd, Status Business Park, Gannaway Lane, Tewkesbury,
Gloucestershire, UK, GL20 8FD*

Web Page: www.status.co.uk, Email: sales@status.co.uk

Technical Support: support@status.co.uk

Tel: +44 (0) 1684 296818, Fax: +44 (0) 1684 293746